

WJ-8718A HF RECEIVER

198.10



FEATURES

- Frequency Coverage from 5 kHz to 30 MHz in One Band
- Fully Synthesized Including BFO
- Five IF Bandwidths Up to 16 kHz
- AM, FM, CW, ISB, USB and LSB Detection Modes
- Modular Construction for Low MTTR and High MTBF
- High Dynamic Range
- More Than 10 Performance Options and 4 Remote Control Options Available
- IEEE 488 and RS-232C/MIL-188C Remote Control Options
- BITE available with MFP Option
- Meets MIL-E-16400 and MIL-S-901C Requirements*

* Contact WJ for Details

DESCRIPTION

The WJ-8718A is the Watkins-Johnson general purpose HF receiver for surveillance and monitoring of RF communications in the 5kHz to 30MHz frequency range. For ease of operation front panel control of: frequency tuning, IF

bandwidth, BFO (± 8 kHz), analog meter input, manual or AGC gain with slow or fast decay times, detection mode and line audio level is provided. Remote control of tuning and IF bandwidth selection is also standard.

Sideband detection provides either independent, upper or lower detection selectable from the front panel. When any of these detection modes are selected, equalized IF sideband filters are automatically switched to provide a separate detection path (paths for ISB), and the BFO is automatically set at the proper injection frequency to recover the intelligence.

Several options are available to enhance the overall capability of the WJ-8718A or satisfy specific requirements. Included in these options are: MFP (Microprocessor Front Panel) which allows digital control of all operations plus scanning of desired memory channels and several remote control options which include IEEE 488 and RS-232C. The aforementioned MFP option comes with BITE (Built In Test Equipment), which tests: $\pm 15V$ power supplies, first and second LO lock/unlock (the LO lock is monitored continuously during receiver operation), bandwidth selection, BFO lock and offset frequency.

All input/output access (with the exception of the phone audio available at a front panel phone jack) is provided at two rear panel terminal strips; included are phone, line and ISB audio outputs. Predetection IF output is provided by a BNC connector, as is a 1 MHz reference output. The reference output may be switched to accept a 1 MHz input.

SPECIFICATIONS

Tuned Frequency	5.0 kHz to 29.99999 MHz															
Display	7 Digit yellow LED 1/2 inch high (see options list)															
Tuning Speeds	Four front panel, pushbutton selected 10 kHz step, 1.2 MHz/turn 1 kHz step, 120 kHz/turn 100 Hz step, 12 kHz/turn 10 Hz step, 1.2 kHz/turn															
Resolution	10 Hz (see options list)															
Stability (Internal Reference)	6×10^{-8} /day, 2×10^{-6} /year															
External Reference	1 MHz, 50 to 500 mV rms into 50 Ω															
Synthesizer Lock-up Time	3 ms typical, 10 ms maximum															
Optional	Calculator format, keypad entry of frequency (optional with MFP)															
Detection Modes	AM – A3-A4A FM – F1-F2-F3-F4 CW – A0-A1 MCW – A2-A4A USB, LSB, ISB (A3A-A3H-A3J-A2A-A2H-A2J) ISB line output 70 mW, 600 Ω balanced															
IF Bandwidths	5 standard front panel selected															
Shape Factor (3 dB to 60 dB)	3 dB bandwidth minimum															
	<table border="1" style="margin-left: auto; margin-right: auto;"> <tr> <td>0.3 kHz</td> <td>1 kHz</td> <td>3.2 kHz</td> <td>6 kHz</td> <td>16 kHz</td> </tr> <tr> <td>7.0:1</td> <td>4.5:1</td> <td>3.0:1</td> <td>2.6:1</td> <td>2.4:1</td> </tr> </table>	0.3 kHz	1 kHz	3.2 kHz	6 kHz	16 kHz	7.0:1	4.5:1	3.0:1	2.6:1	2.4:1					
0.3 kHz	1 kHz	3.2 kHz	6 kHz	16 kHz												
7.0:1	4.5:1	3.0:1	2.6:1	2.4:1												
IF Output	455 kHz 20 mV minimum into 50 Ω for an input signal $> 3 \mu\text{V}$ (see options list)															
Gain Control Mode	Manual, AGC fast and slow															
Range	100 dB minimum															
AGC threshold	3.0 μV typical															
AGC attack time	15 ms typical															
AGC release time	Fast – 25 ms maximum Slow – 4 seconds maximum															
BFO	± 8 kHz range															
Display	2 digit															
Resolution	100 Hz (see options list)															
Optional	Keypad entry of frequency offset, 10 Hz resolution															
Sensitivity, 200 kHz - 30 MHz																
CW	<table border="1" style="margin-left: auto; margin-right: auto;"> <tr> <th>IF BW</th> <th>Input Signal</th> <th>(S+N)/N at Audio Out</th> </tr> <tr> <td>0.3 kHz</td> <td>0.40 μV</td> <td>16 dB</td> </tr> <tr> <td>6 kHz</td> <td>1.7 μV/50% mod. 400 Hz</td> <td>10 dB</td> </tr> <tr> <td>16 kHz</td> <td>2.5 μV/400 Hz mod. 4.8 kHz peak dev.</td> <td>17 dB</td> </tr> <tr> <td>3.2 kHz</td> <td>.56 μV</td> <td>10 dB</td> </tr> </table>	IF BW	Input Signal	(S+N)/N at Audio Out	0.3 kHz	0.40 μV	16 dB	6 kHz	1.7 μV /50% mod. 400 Hz	10 dB	16 kHz	2.5 μV /400 Hz mod. 4.8 kHz peak dev.	17 dB	3.2 kHz	.56 μV	10 dB
IF BW	Input Signal	(S+N)/N at Audio Out														
0.3 kHz	0.40 μV	16 dB														
6 kHz	1.7 μV /50% mod. 400 Hz	10 dB														
16 kHz	2.5 μV /400 Hz mod. 4.8 kHz peak dev.	17 dB														
3.2 kHz	.56 μV	10 dB														
AM																
FM																
ISB	ISB Filter Characteristics: 2950 Hz at 6 dB points minimum, equalized to 2000 μs group delay. Bandpass ripple ± 1.5 dB maximum. (60 dB Bandwidth, 4.7 kHz) (F)															
CW Sensitivity, 5 kHz – 200 kHz																
(0.3 kHz IF Bandwidth)																
50 kHz – 200 kHz	A 0.63 microvolt signal will produce at least a 16 dB (S+N)/N ratio at the Audio output.															
15 kHz – 50 kHz	A 1.4 microvolt signal will produce at least a 16 dB (S+N)/N ratio at the Audio output.															
5 kHz – 15 kHz	A 63 microvolt signal will produce at least a 16 dB (S+N)/N ratio at the Audio output.															
Signal Handling Capabilities																
3rd Order Input Intercept Point	+20 dBm, minimum for signals separated by > 30 kHz.															
Reciprocal Mix	IF BW 3.2 kHz, desired sig. of 25 μV (–79 dBm) with undesired signal of 79 mV (–9 dBm) Δf from desired > 30 kHz, noise ratio (S+N)/N ≥ 20 dB.															
Cross Modulation	IF BW 1.0 kHz, desired signal of 10 μV (–87 dBm) with undesired signal 31.6 mV (–17 dBm) Δf from desired > 50 kHz and 30% AM, $< 10\%$ cross modulation.															
Internal Spurious Responses	All internal spurious responses are less than –114 dBm referred to the input above 50 kHz tuned frequency.															

IF Rejection	Greater than 90 dB
Image Rejection	Greater than 90 dB
Audio Outputs	
Power Output	For a 3 μ V 30% AM signal 600 Ω unbalanced Line Audio 1W minimum.
Amplifier response	\pm 1.5 dB from 100 Hz to 8 kHz, 1 kHz reference frequency
Distortion	< 5% at rated output.
Headphone Output	30 mW minimum into 600 ohm phones.
FM/CW Output	DC coupled low level output from FM/CW detector is provided on the rear panel.
Power Interrupt	Programmed and operating parameters are retained during power interrupts up to 48 hours and restored upon resumption of power.
Analog Metering	Front panel selectable line audio or signal strength monitoring.
Antenna Input	
Impedance	50 Ω unbalanced, nominal
Protection	Will withstand the effects of RF power up to +30 dBm and static build up. The circuit automatically resets.
Conducted Oscillator Radiation	-87 dBm, maximum
Operating Temperature Range	0 $^{\circ}$ C to +50 $^{\circ}$ C.
Power Requirements	115/220 V AC \pm 15%, 48-410 Hz, 70 watts nominal 100 watts with maximum options installed.
Weight	Approximately 35 pounds (15.75 kg)
Size	5.25 inches high (13.34 cm)
	19 inches wide (48.26 cm)
	19.4 inches deep (49.28 cm)

Note: All μ V measurements referenced to 50 Ω impedance.

WJ-8718A OPTIONS*

Nomenclature

Description

- (F) – Field installation kit is available
- (C) – Contact factory for installation requirements

WJ-871XA/NAV	Special Environment Configuration meets MIL-E-16400 and MIL-S-901C requirements*
WJ-871XA/B10	10 Hz BFO. Provides an additional thumbwheel switch to increase the BFO tuning resolution to 10 Hz. (F)
WJ-871XA/1Hz	1 Hz Tuning Resolution. Allows 1 Hz tuning resolution with either manual or remote control options. (C)
WJ-871XA/SMO	Signal Monitor Output. An additional rear panel 455 kHz output with 28 kHz BW minimum. (C)
WJ-871XA/MFP	Microprocessor Front Panel. Provides manual control of tuned frequency or BFO via keypad or rotary tuning controlled optical encoder; LED indicating pushbutton switches control all other receiver functions. Included are 99 memory channels and memory scan capabilities. (C)
WJ-871XA/PRE	Preselector. Automatic preselection of 10 suboctave filters, enhances 2nd order intermodulation characteristic. PRE insertion loss modifies sensitivity. (F)
WJ-871XA/COR	Carrier Operated Relay. Switched circuitry provided for external use. Threshold is front-panel adjustable and LED indicator displays COR closure. (C)
WJ-871XA/RED	Red frequency readout display color. (F)
WJ-871XA/GRN	Green frequency readout display color. (F)
WJ-871XA/LLA	Low level audio option. Provides 1W nominal audio line output switchable to 1 mW (0 dBm) nominal. Distortion <2% in low level output. ISB line output switchable to 1 mW (0 dBm) nominal if installed.
WJ-871XA/FSK	Frequency Shift Keying Demodulator. Provides demodulation of binary FSK signals with shifts of less than 50 Hz to greater than 2000 Hz. Provides for tuning indicators on front panel meter. Bipolar EIA or MIL compatible outputs or monopolar TTL/CMOS — (F).
WJ-871X/DDC	Dual Diversity AGC comparison and decision circuit
WJ-871X/MON	Monitor Output provides operational information at rear panel. Word format and logic are compatible with COM option allowing master/slave operation. (F)
WJ-871X/IPP	Input Power Protection. The IPP option offers RF input protection from signals of +20dBm and above, with automatic reset.

*Certain combinations of options may require an additional software change. Consult factory for details.

WJ-8718A – REMOTE CONTROL OPTIONS

Nomenclature

Description

WJ-871XA/232	RS-232-C Bidirectional Asynchronous Communication. Optionally compatible with MIL-STD-188C. Allows master/slave operation via dip switch selection. (F)
WJ-871XA/488	IEEE-488/1975 Parallel Interface utilizing the General Purpose Interface Bus (GPIB) defined in IEEE Standard 488-1975. This is a bidirectional interface. (Listen/Talk)(F)
WJ-871XA/COM	Command Input. Allows remote control of receiver tuned frequency, IF bandwidth, detection and gain modes via 37 parallel input lines. CMOS levels required. Word format and logic are compatible with MON option allowing master/slave operation. (F)
WJ-871XA/232M	RS-232-C Remote control option for use with WJ-8718A/MFP. (F)
WJ-871XA/488M	IEEE-488 Bidirectional Remote control option for use with WJ-8718A/MFP. (F)

*Contact WJ for details. (F) – Field installation kit is available

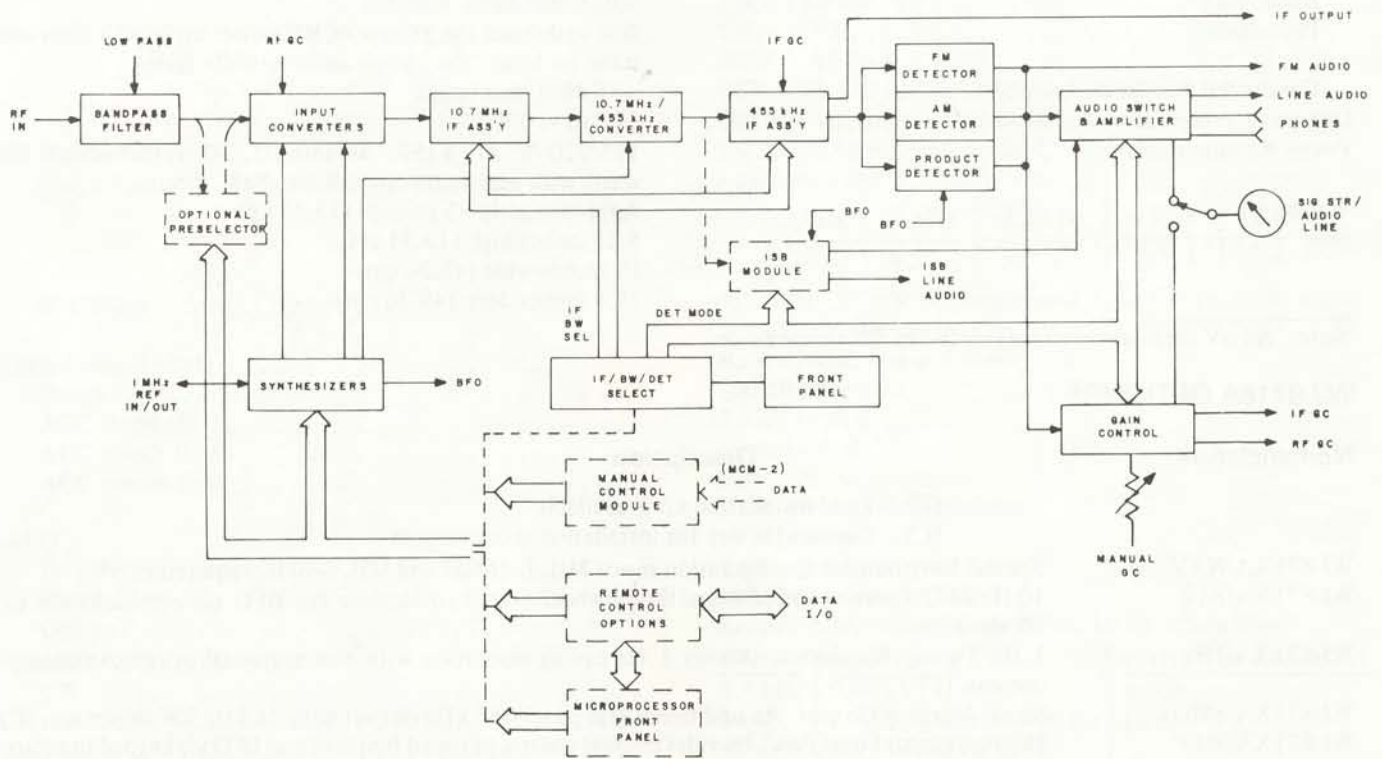

WJ-8718A RECEIVER MAINFRAME SIMPLIFIED BLOCK DIAGRAM